

VAPOR PIPE SHIELD™ & OIL-LESS AIR COMPRESSOR PACKAGE FOR DRY & PRE-ACTION FIRE SPRINKLER SYSTEMS

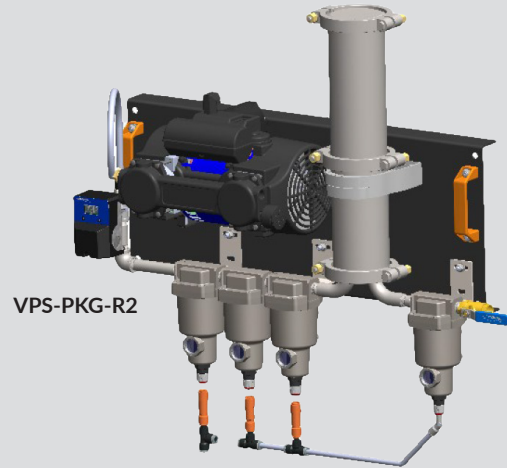
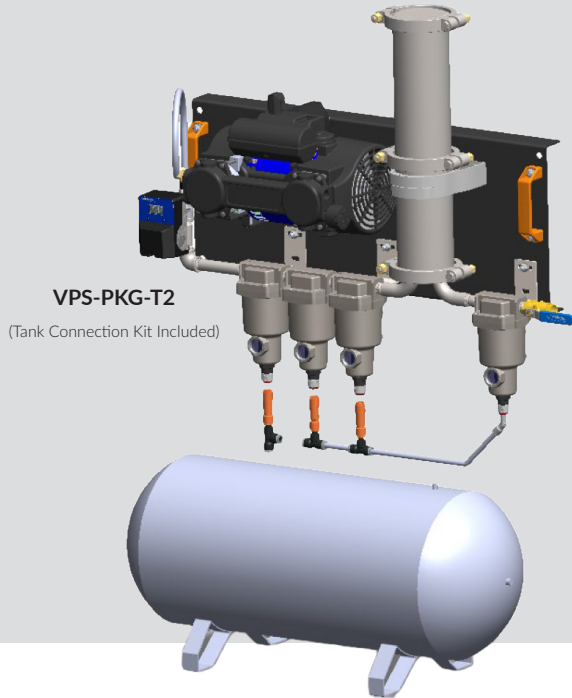

About the Vapor Pipe Shield™ and Compressor Package

Vapor Pipe Shield™ is a Patented and UL Listed innovative solution for the prevention of corrosion in dry-pipe & pre-action fire sprinkler systems. Vapor Pipe Shield™ is a delivery system of Vapor phase Corrosion Inhibitor (VpCI®), a technology backed by over forty years of established science. Vapor Pipe Shield™ is fully mechanical with no electrical connections and simply piped directly in-line between the air compressor and the dry pipe valve.

General Air Products newly improved OL Plus Series Oil Less Riser Mount Fire Protection Air Compressors are specifically designed to fill dry pipe and pre-action fire sprinkler systems to supervisory pressure within 30 minutes per NFPA 13.

Features

- Fire Protection Air Compressors
- DPS Select: Pre-set Digital Pressure Switch at .9 / 1.24 bar (13 / 18 PSI) & 3.4 / 4.1 bar (50 / 60 PSI)
- Wall Mount or Tank and Connection Package

Included
DPS Select

- ONLY UL-Listed Digital Pressure Switch in the Fire Protection Industry
- Easily Adjust Pressure Settings In The Field
- 2 Pre-Set Pressures to choose from

Model	Tank Size	Pre-Set Pressure (bar)	Fill Capacity @ 1.37 bar (Liters)	Total System Capacity (L)	LPM @ .7 bar	Motor (kW)	Voltage	Amperage		Recommended Wire Size (mm ²)		
								FLA	Start Up	8m	15m	30m
VPS-PKG-R2	No Tank	.9 / 1.24	3,785	15,141	171	.75	220-240	7.5	53	3	3	6
VPS-PKG-T2	45 Liter	.9 / 1.24	3,785	15,141	171	.75	220-240	7.5	53	3	3	6

*Fill Capacity is based on the packaged Vapor Pipe Shield™ unit's coverage capability. Compressor fill capacity is slightly more than specified.



Any questions about this product please reach out to your Victaulic rep

VAPOR PIPE SHIELD™ & OIL-LESS AIR COMPRESSOR PACKAGE

FOR DRY & PRE-ACTION FIRE SPRINKLER SYSTEMS

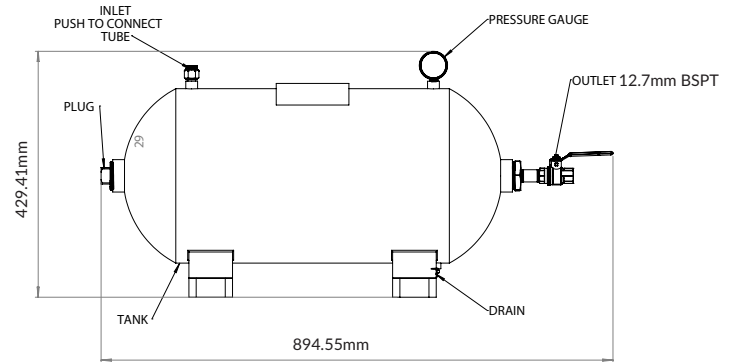
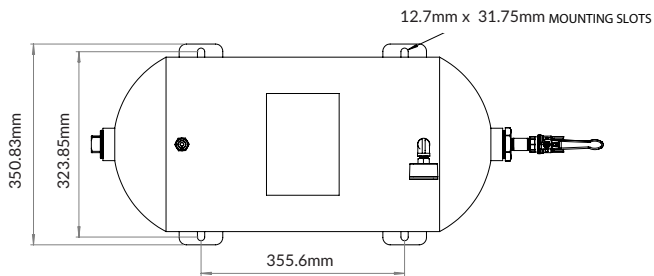
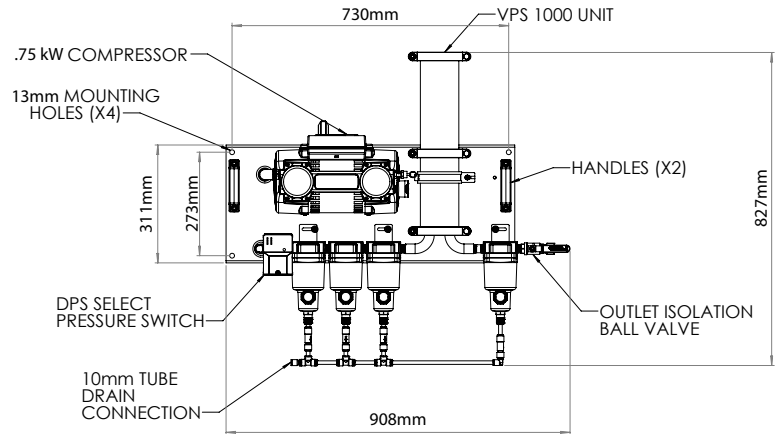
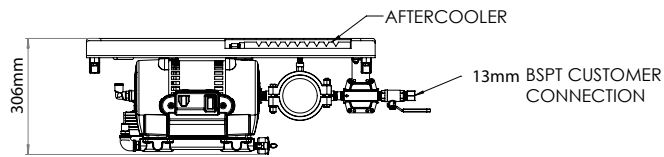

Model	Tank Size	Pre-Set Pressure (bar)	Fill Capacity @ 1.37 bar (Liters)	Total System Capacity (L)	LPM @ .7 bar	Motor (kW)	Voltage	Amperage		Recommended Wire Size (mm ²)		
								FLA	Start Up	8m	15m	30m
VPS-PKG-R2	No Tank	.9 / 1.24	3,785	15,141	171	.75	220-240	7.5	53	3	3	6
VPS-PKG-T2	45 Liter	.9 / 1.24	3,785	15,141	171	.75	220-240	7.5	53	3	3	6



generalairproducts.com

800.345.8207