

Manual

Elma 6620 Process Multimeter

EAN: 5706445874002

ENGLISH





Warning

FA2—E100253/ VER(1.1)/ NUM(1/1)

THIS IS AN IEC SAFETY CLASS 1 PRODUCT. THE GROUND WIRE IN THE LINE CORD MUST BE CONNECTED FOR SAFETY.

WARRANTY

Our company warrants to the original purchaser that each product it manufactures will be free from defects in material and workmanship under normal use and service for a period of one year from date of purchase. Our company's warranty does not apply to fuses, test leads or any product which, in our company's opinion, has been misused, altered, or damaged by accident or abnormal conditions of operation or handling.

To obtain warranty service, contact the nearest Service Center or send the product, with a description of the difficulty, and postage prepaid, to the nearest Service Center. We assume no risk for the damage in transit. We will, at its option, repair or replace the defective product free of charge or refund your purchase price. However, if we determine that the failure was caused by misuse, alterations, accident or abnormal condition of operation or handling, you will be billed for the repair and the repaired product will be returned to you transportation prepaid.

SHIPPING TO MANUFACTURER FOR REPAIR OR ADJUSTMENT

All shipment of our company's instruments should be made via United Parcel Service or "Best Way" prepaid. The instrument should be shipped in the original carton; or if it is not available, use any suitable container that is rigid and of adequate size. If a substitute container is used, the instrument should be wrapped in paper and surrounded with at least four inches of excelsior or similar shock-absorbing material.

CLAIM FOR DAMAGE IN SHIPMENT TO ORIGINAL PURCHASER

The instrument should be thoroughly inspected immediately upon original delivery to purchaser. All material in the container should be checked against the enclosed packing list. The manufacturer will not be responsible for shortages against the packing sheet unless notified immediately. If the instrument is damaged in any way, a claim should be filed with the carrier immediately.

To obtain a quotation to repair shipment damage, contact the nearest Service Center. Final claim and negotiations with the carrier must be completed by the customer.

Contents

Brief introduction	1	Input and output plugholes	8
General description	1	Application of Display HOLD	9
Open-package inspection	1	Application of relative measurement (REL).....	9
Safety warning	1	Range selection	10
Symbols	2	Speed selection.....	10
Understanding of the meter.....	3	Use of the meter	10
Meter panel	3	The measuring function of the meter.....	11
Starting up.....	3	Measurement of AC voltage	11
Automatic shutdown	3	Measurement of VFC voltage.....	11
Display of low battery power.....	3	Measurement of DC voltage.....	11
Turn on the backlight	4	Measurement of DCmV voltage.....	11
Automatically turn off the backlight	4	Measurement of resistance	12
Turn on the flashlight	4	On-off test	12
Automatically turn off the flashlight	4	Measurement of diodes.....	12
Rotary switch	4	Measurement of DC current	13
Buttons	5	Measurement of AC current	13
Display screen.....	7	Measurement of loop current.....	13
		Output functions of the meter	14

Current output	14	General characteristics.....	22
Constant current output (SOURCE mode)	15	Detailed precision indexes.....	24
Constant current output (SIMULATE mode)	16	Detailed precision indexes for measurement	24
Voltage output	16	Detailed precision indexes for output	26
Frequency output	17	Input characteristics.....	28
Modification of meter settings	17	Notice of the Instruction Manual.....	28
Brief introduction.....	17		
Selection of setting items	18		
Meter maintenance	19		
General maintenance.....	19		
Battery replacement	19		
Fuse replacement	20		
Technical specification	22		
Safety and conformity.....	22		

Change log

Date/issue	Responsible	Description
2025-09-16	SMK	First issue.

Chapter one

Brief introduction

⚠Warning

Please read this manual carefully before using the meter.

General description

This meter is an industrial, battery-powered instrument for field maintenance, an integration of a digital multi-meter and process signal sources.

It conforms to safety standards of 600V CAT.IV and 1000V CAT.III defined in IEC 61010-1 Safety Requirements for Electrical Equipment for Measurement, Control, and Laboratory Use.

It is designed with a dual-color plastic enclosure of IP65, for application in harsh environment.

It has the following functions:

- **Measurement functions:**
Measurement of AC voltage, DC voltage, Ohm, capacitance, DC current, AC current, on-off, diodes, frequency;
Built in VFC low-pass filter can accurately measure distorted voltage and variable frequency voltage.

Data display and retention;
Measurement of relative values

- **Output functions:**
Output of DC voltage, frequency, and DC current (constant output, manual stepping and SIMULATE);
- **Loop inspection:** supply power to 24V circuits and meanwhile measure current.

Open-package inspection

Check the product to find out whether it is damaged during transportation. Check the completeness of the product, and keep package materials well for future transportation.

Standard accessories, as well as optional ones, of the meter are listed below. Optional accessories can be purchased as needed.

Standard accessories:

- One pair of testing wires (including an alligator clip)
- One operating manual
- Three 1.5V alkaline cells (LR6)
- One 630mA/250V quick-acting fuse

Safety warning

This meter is designed, produced and inspected as per IEC 61010-1. This manual contains warning issues and

safety regulations that users must obey to guarantee safe application and working status of the meter. Please read the following instructions before use.

The label  marked on the meter means that the meter must be operated according to relevant instructions in this manual for safety purposes.

Warning refers to an activity that may endanger the user;







Caution refers to an activity that may damage the meter or the tested equipment;

Notice refers to necessary understanding of meter operations and characteristics. Please see table 1-1 for explanation of international symbols adopted on the meter and in the manual.

Symbols

Please see table 1-1 for explanation of international symbols adopted on the meter and in the manual.

Table 1-1 International symbols



Symbol	Meaning	Symbol	Meaning
	AC		Grounding
	DC		Fuse
	AC and DC		Double insulation
	Battery		
CAT III	Overvoltage category three, with pollution grade two (as per IEC 61010) refers to protective electrical level of supplied impulse withstand voltage. Typical installation positions include: equipment with fixed three-phase distribution circuits (including single commercial lighting circuit); lighting equipment and lines inside large-scale buildings; industrial field equipment.		
CAT IV	Overvoltage category four, with pollution grade two (as per IEC 61010) refers to protective electrical level of supplied impulse withstand voltage. Typical installation positions include: any outdoor supply line or device of three-phase public power supply units; any outdoor power transmission line; equipment for front-side overcurrent protection of power meters.		

battery power. Please replace the battery as soon as possible.

⚠Warning

To avoid electric shock or personal injury due to incorrect readings, please replace batteries immediately when the symbol  is shown on the screen.



Turn on the backlight

Press the  key to turn on the backlight, and press the  key again to turn off the backlight.

Automatically turn off the backlight

The meter is set at the factory so that if the user does not turn off the backlight of the meter within 60 seconds, the meter will automatically turn off the backlight. Whether to use the auto-off backlight function can be set by the user (see Chapter 4 "Setting Function").

Turn on the flashlight

Press and hold the  key (more than two seconds) to turn on the flashlight, and the screen displays . Press and hold the  button again (more than two seconds) to turn off the flashlight.

Automatically turn off the flashlight

The meter is set at the factory: if the user does not turn off the meter torch within 5 minutes, the meter will automatically turn off the torch. Whether to use the automatic flashlight off function can be set by the user (see Chapter 4 "Setting Function").

Rotary switch

Turn the rotary switch to any a function position to start the meter. And then, the meter will give a standard display of this function on the screen.

Measurement functions are marked with white characters while output functions are marked with yellow ones.

Select functions marked in blue on the rotary switch with the blue button.

When the rotary switch is turned to a new function position, information on the new function will be shown on the screen. Settings for a function are only applicable to this function, and will not influence any other function.

Figure 2-2 shows the rotary switch. Descriptions of relevant positions are listed in table 2-1.

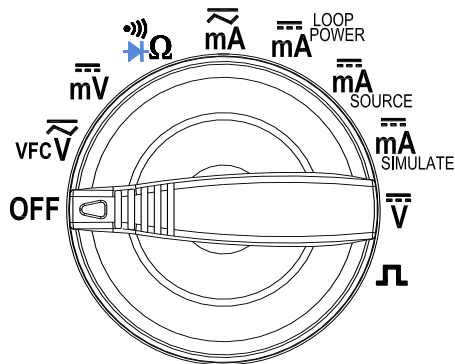

Figure 2-2 Rotary switch

Table 2-1 Rotary switch

Pos.	Rotary switch function	Blue button function
VFC \tilde{V}	Measurement of DC voltage (DCV)	Measurement of AC voltage (ACV) Measurement of AC voltage (VFC)
mV	Measurement of DC millivolt voltage (DCmV)	None
Ω	Resistance measurement	Measurement of diodes, on-off

\tilde{mA}	Measurement of DC current (DCmA)	Measurement of AC current (ACmA)
\tilde{mA} LOOP POWER	Measurement of loop current (loop power supply)	None
\tilde{mA} SOURCE	Current output	
\tilde{mA} SIMULATE	Simulated transmitter	
\tilde{V}	Output of DC voltage	
\square	Output of frequency	

Buttons

Buttons are shown in figure 2-3. Relevant descriptions are shown in table 2-2.

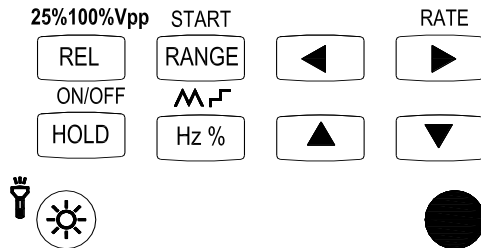









Figure 2-3 Buttons

Table 2-2 Buttons

Button	Description
	<p>Under measurement: push this button to exit from the automatic mode (AUTO) and enter into the manual range mode; under the manual mode, select an input range and keep pressing the button for at least 2 seconds to enter the automatic range mode.</p> <p>Under the voltage and frequency output: select a fixed output range.</p> <p>Under thermocouple and thermal resistance output: select an indexing number.</p> <p>Under current output: start and stop automatic output of current waveforms.</p>
	<p>Under measurement: press this button to save the current reading as an error reference value. Subsequent readings are difference values with respect to this reference value; press again the button to show a difference value in percentage; then press it again to exit.</p> <p>Under output: for non-automatic output of current waveforms, select the mode of 25%, 100% or digit-setting output.</p> <p>Under frequency output: switch over the</p>

	display of amplitude of output frequency.
	<p>Under measurement: for data retention.</p> <p>Under output: output connected (displaying ON) or disconnected (displaying OFF)</p>
	<p>Under ACV measurement: select the measurement of frequency or duty cycle.</p> <p>Under output: for output of automatic current waveforms, select the mode of automatic ramp M, automatic stepping F, or digit-setting output.</p> <p>Under frequency output: switch over the display of output frequency values.</p>
	Select leftwards the output setting digit;
	<p>For digit-setting output: Select rightwards the output setting digit;</p> <p>Under measurement: change measuring speed.</p> <p>Under output:</p>
	<p>For digit-setting output: increase the value of a setting digit;</p> <p>For stepping output: every time the button is pressed, the output will be stepped up linearly by 25% or 100%.</p>

▼	For digit-setting output: decrease the value of a setting digit; For stepping output: every time the button is pressed, the output will be stepped down linearly by 25% or 100%.
●	Select the blue-button function

Display screen

Figure 2-4 and table 2-3 are for description of the display screen.

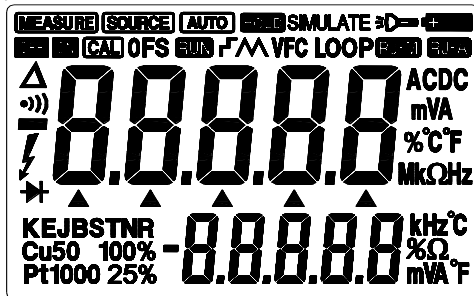







Figure 2-4 Display screen

Table 2-3 Display screen

Display	Description
MEASURE	The meter works under the measurement mode
SOURCE	The meter works under the output mode
AUTO	The meter works under the mode of measurement with an automatic range
HOLD	Measurement data retention
SIMULATE	The meter works under the simulated transmitter mode.
☰	Turn on the flashlight
+	Battery low
LOOP	Start the loop power of 24V
RUN	Start automatic waveform output
VFC	low pass filtering
F S	Under measurement: show measuring speed (fast or slow)

OFF ON	Under output: indicate connected output (ON) and disconnected output (OFF)
AC DC	Alternate and direct current
Ω 、k Ω 、M Ω	Units of resistance: ohm, kilohm and megohm
Hz、kHz	Units of frequency: hertz, kilo-hertz and megahertz
mA	Units of current: ampere, milliampere and microampere
V、mV	Units of voltage: volt and millivolt
%	Relative measurement (REL) to show relative percentage
▲▲▲▲▲	Output setting digit
kHz % Ω mV	Auxiliary display units
-0000	Auxiliary display
25% 100%	Under the output mode: it means 25% or 100% stepping output of DCmA

	ramp output of current
 	Under measurement: test on and off; Under measurement: test diodes
	Under measurement: measure relative values.
-00000	Main display
	Under measurement: indicate input voltage is higher than 30V

Input and output plugholes

Figure 2-5 and table 2-4 are for description of input and output plugholes.

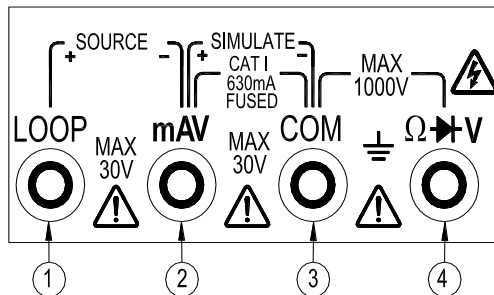



Figure 2-5 Input and output plugholes

Table 2-4 Input and output plugholes

No.	Plughole	Description
1	LOOP	Input point for loop power supply;
2	mA	Input for current measurement; Common point for DC current output; Common point for loop power supply; For output of a simulated transmitter (in series with external power supply) With 630mA fuse protection
3	COM	Common point for all tests; Common point for simulated transmitter output
4	VΩ↔	Test terminal of voltage up to 1000V, Ω, capacitance, frequency, thermocouple, thermal resistance, diode and on-off.



Application of Display HOLD

When the meter is under the measurement mode, press the  button to enter the mode of display hold. Then the meter will keep current readings in the display zone unchanged (the symbol  will be shown on the screen).

Press again the  button to exit from display hold.

Application of relative measurement (REL)

When the meter is under measurement, selection of the relative mode will make the current reading kept as a reference value for subsequent measurement, and then make it reset to be zero.

- Press the button  once to select the relative mode (if the current display is “OL”, the relative mode can't be selected). After entering the relative mode, the meter will start the manual range mode.
The reference value will be displayed on the auxiliary screen, while the main screen will show the difference between the new measurement reading and the reference value.
- Press again the button  to show the percentage of relative values. The auxiliary screen will show the reference value, while the main screen will display the percentage of difference between the current measurement reading and the reference value, which is:

$$REL\% = \frac{\text{Current reading} - \text{reference value}}{\text{Reference value}} * 100\%$$

Under the relative mode (REL %), the screen will show $\Delta\%$.

- Press the button  for the third time to exit from the relative mode.





Warning

Please be careful under the REL mode, due to the possible existence of dangerous voltage.

Range selection

Under the measurement mode of the meter, press the button  to select a fixed range.



When a new function is switched on, the meter will adopt the automatic range mode by default (with the symbol  on the screen). Under the automatic range, the meter will select a range as low as possible to guarantee the most precise readings (highest resolution ratio).

If the meter is under the automatic range mode () , press the button  to switch it to the manual range (current range). Then, press again the button  to select a new range. Keep pressing the button  for at least 2 seconds to recover the meter to the automatic range mode

().

Notice

Under functions of diodes, on-off test, capacitance, frequency and duty cycles, pressing the button  will not be valid. RTD and TC are only prepared with manual ranges.

Under the output functions, as to voltage and frequency output, press the button  to select a fixed output range; as to thermocouple and thermal resistance output, press the button  to select an indexing number.

Speed selection

Slow measurement is adopted by default. Under measurement, press the button  to change the measurement speed.

Chapter three

Use of the meter

This chapter introduces how to use the meter.

Most functions can be selected for use through the rotary switch.

White characters beside the rotary switch indicate the

major functions, while blue ones indicate the alternative functions. Such alternative functions can be applied by pressing the blue button.

The measuring function of the meter

MEASURE is displayed in the upper left corner of the screen.

Measurement of AC voltage

1. Turn the rotary switch to the position of “ $\sqrt{\text{VFCV}}$ ” and then press the blue button to choose the function of measuring AC voltage;
2. Plug the black probe into the plughole of “COM” and the red probe into “ $\Omega \rightarrow V$ ”.
3. Connect probes to the circuit to be measured, and read the stable measurement data.
4. Press the button  to display frequency and duty cycle of the signal to be measured.

Measurement of VFC voltage

1. Turn the rotary switch to the position of “ $\sqrt{\text{VFCV}}$ ” and then press the blue button to choose the function of measuring VFC voltage;
2. Plug the black probe into the plughole of “COM” and the red probe into “ $\Omega \rightarrow V$ ”.

3. Connect probes to the circuit to be measured, and read the stable measurement data.

Measurement of DC voltage

1. Turn the rotary switch to the position of “ $\overline{\text{VFCV}}$ ”;
2. Plug the black probe into the plughole of “COM” and the red probe into “ $\Omega \rightarrow V$ ”.
3. Connect probes to the circuit to be measured, and read the stable measurement data.

Warning

- Don't input voltage higher than DC 1000V or AC 750Vrms. It is possible to show higher voltage, but with risks of damaging the meter.
- In the case of input voltage higher than 30V, the screen will show the symbol of ⚡ as a safety warning.



Measurement of DCmV voltage

1. Turn the rotary switch to the position of “ $\overline{\text{mV}}$ ”.
2. Plug the black probe into the plughole of “COM” and the red probe into “ $\Omega \rightarrow V$ ”.
3. Connect probes to the circuit to be measured, and read the stable measurement data.

Measurement of resistance

Warning

To avoid damage to the meter as well as to the equipment under test, cut off all the power supply of the circuit and discharge all capacitors completely, before measurement of resistance.

1. Turn the rotary switch to the position of “”
2. Plug the black probe into the plughole of “COM” and the red probe into “”.
3. Connect probes to the circuit to be measured, and read the stable measurement data.

Notice



- When the resistance to be measured is in an open circuit, or it is beyond the maximum range of the meter, the screen will show **OL**.
- As the output test current of the meter passes through all possible paths between probes, the resistance measured normally differs from its rated value.

On-off test

Warning

To avoid damage to the meter as well as to the



equipment under test, cut off all the power supply of the circuit and discharge all capacitors completely, before on-off testing is conducted.

1. Turn the rotary switch to the position of “”, and press the blue button to select the function of on-off test;
2. Plug the black probe into the plughole of “COM” and the red probe into “”.
3. Connect probes to the circuit under test. If the circuit is connected (with resistance lower than about 50Ω), the buzzer beeps.

Measurement of diodes

Warning

To avoid damage to the meter as well as to the equipment under test, cut off all the power supply of the circuit and discharge all capacitors completely, before measurement of diodes.

1. Turn the rotary switch to the position of “”, and press the blue button to select the  measurement;
2. Plug the black probe into the plughole of “COM” and the red probe into “”.

3. Connect probes to the diode to be measured, and read the stable measurement data.

Forward test: connect the red probe to the positive pole of the diode under test and the black probe to the negative pole. The screen shows the approximate forward voltage drop, normally about 0.5~0.8V.

Reverse test: connect the red probe to the negative pole of the diode under test and the black probe to the positive pole. In normal cases, the screen will show **OL**.

Measurement of DC current

⚠Warning

To avoid damage to the meter as well as to the equipment under test, make sure positions of the rotary switch and the input terminals of probes are consistent with the required measurement mode.

1. Turn the rotary switch to the position of “ **\overline{mA}** ”;
2. Plug the black probe into the plughole of “COM” and the red probe into “mAV”.
3. Connect probes to the circuit to be measured, and read the stable measurement data.

Measurement of AC current

⚠Warning

To avoid damage to the meter as well as to the equipment under test, make sure positions of the rotary switch and the input terminals of probes are consistent with the required measurement mode.

1. Turn the rotary switch to the position of “ **\overline{mA}** ”, and press the blue button to select the measurement of AC current;
2. Plug the black probe into the plughole of “COM” and the red probe into “mAV”.
3. Connect probes to the circuit to be measured, and read the stable measurement data.

Measurement of loop current

This function can be used to measure current under constant 24VDC voltage.

The function of 24V loop measurement can be used for measuring the transmitter loop. (The meter can be connected to the transmitter, instead of connecting the signal regulator or the transmitter to the circuit.)

⚠Warning

The typical loop power supply is of 24VDC. Voltage

between terminals may exceed 24V, which depends on specific conditions, such as loop current and internal series resistance.

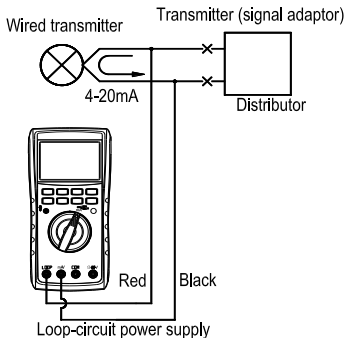

Figure 3-1 Measurement of loop current

1. Turn the rotary switch to the position of $\overline{\text{mA}}$ ^{LOOP POWER}, and the screen will show “LOOP”;
2. Plug the black probe into the plughole of “mAV” and the red probe into “LOOP”;
3. Connect probes to the circuit to be measured, and then read the stable measurement data.

Output functions of the meter

Output of simulated resistance, simulated thermal resistance, DC voltage, thermocouple, frequency and current set by the user can be realized.

SOURCE is displayed in the upper left corner of the screen.

⚠Warning

Don't apply voltage at the output end, as improper voltage at the output end can cause damage to internal circuits.

Current output

This meter can output DC current of 0~33 mA

Two output modes are available:

SOURCE mode: current comes from the meter.

SIMULATE mode: current comes from external voltage.

Two configuration modes are available:

Constant current output: specified current is output continuously

Manual stepping output: output current is stepped up or down by 25% or 100%.

The SOURCE mode is used for current supply to passive circuits (loops without power supply). It will consume more battery energy to use the meter as current source (the SOURCE mode), compared to the SIMULATE mode, and therefore the SIMULATE mode should be used whenever possible.

⚠Warning

Don't apply voltage of 30V or above on output terminals or electric shock can occur.







In addition, keep voltage between the circuit and the earth below 30V. Be sure to use probes and lead wires originally attached to the meter (check to find out whether they are suitable for relevant measurement).



⚠Warning

Except in the SIMULATE mode, don't apply voltage on output terminals, as improper voltage applied can damage internal circuits.

Constant current output (SOURCE mode)

1. Turn the rotary switch to the position of "mA", and the screen will show "SOURCE" and "LOOP". The output is set to be 0mA;
2. Plug the black probe into the plughole of "mAV" and the red probe into "LOOP";
3. Connect the lead wire to the circuit to be measured.
4. Press the button  to select the indicative value for non-automatic output of current waveforms, and units of 'mA' and '25%' (or '100 %') will be shown, among which the value for 0 % is 4mA while that for 100 % is

20mA. Under the mode of digit-setting output, press button  or  to select the output setting digit; press button  or  to automatically increase or decrease the setting digit; keep pressing the button for 1 second and after that the value can be changed continuously. Under the mode of 25% (or 100%) output, press the button  or  to change the value of the setting digit. Press the button , and 'ON' will be shown before the output value, indicating that current output starts.

5. Press the button  to select the indicative value for automatic output of current waveforms, and units of 'mA', 'M SLOW' and 'M FAST' (or 'F') will be shown. Press the button  to connect or disconnect output and meanwhile to show 'ON' or 'OFF'. Press the button  to start or stop the automatic output of waveforms. If automatic waveform output is started, the screen will show 'AUTO', and if it is stopped, the current output value will be held and the meter will enter the digit-setting output mode.

Constant current output (SIMULATE mode)

When the SIMULATE function is enabled, the meter can take up certain current from the external voltage source through the SIMULATE(+) terminal. The meter can be used to simulate a two-wire transmitter in loop tests.

⚠ Notice

The meter can be connected to test a transmitter or a signal regulator, instead of connecting the transmitter.

When current from external power supply is 20mA, keep the voltage within 15~48V.

⚠ Warning

Before connecting the test wires to the current circuit, turn the rotary switch to any position of milliampere output. Otherwise, low impedance caused when the rotary switch is at other positions may influence the circuit and bring about current up to 35mA in the circuit.

Please apply voltage according to figure 3-2. Don't connect inversely.

1. Turn the rotary switch to the position of “ $\overline{\text{mA}}_{\text{SIMULATE}}$ ”, and the screen will show “SOURCE” and “SIMULATE”. The output is set to be 0mA;
2. Plug the black probe into the plughole of “COM” and

the red probe into “mAV”.

3. Connect the lead wire to the circuit to be measured.
4. Operations of other buttons are the same as those mentioned in constant current output.

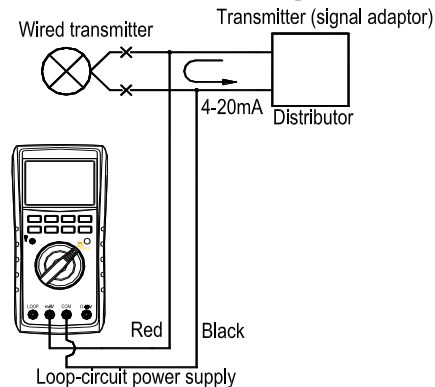











Figure 3-2 Current output in the SIMULATE mode



Voltage output







1. Turn the rotary switch to the position of “ $\overline{\text{V}}$ ”, and the screen will show “SOURCE”;
2. Plug the black probe into the plughole of “COM” and the red probe into “mAV”.
3. Connect the probes to the input end of the user meter;

- Press the button  to select a range of 100mV, 1V or 10V;
- Press the button  or  to select output setting digit; press  or  to change the setting digit which can automatically increase or decrease. Keep pressing the button, and after 1 second, the value can be changed continuously.
- Press the button  to connect or disconnect the output, and meanwhile to show 'ON' or 'OFF'.

Frequency output

- Turn the rotary switch to the position of “”, and press the blue button to select frequency output. Then the screen will show “SOURCE” and the unit ‘Hz’;
- Plug the black probe into the plughole of “COM” and the red probe into “mAV”.
- Connect the probes to the input end of the user meter;
- Press the button  to select the relevant output range: 1~100 Hz, 0.1~1.1kHz, 1.00~6.00kHz and 6.0~11.0 kHz;
- Frequency value setting:
Press the button  or  to select the setting digit;

press the button  or  to change the setting digit which can automatically increase or decrease. Keep pressing the button and after 1 second, the value can be changed continuously;

- Press the  key to enter the frequency amplitude setting mode, the lower part of the display shows that the default amplitude is 1V.
- Frequency amplitude setting:
Press the button  or  to select the setting digit; press the button  or  to change the setting digit which can automatically increase or decrease. Keep pressing the button and after 1 second, the value can be changed continuously;
- Press the  key again to enter the frequency setting.
- Press the button  to connect or disconnect the output, and meanwhile to show ‘ON’ or ‘OFF’ .

Chapter four

Modification of meter settings

Brief introduction

Default factory settings can be changed through the modification.

Some settings are general and applicable to all functions,

while some are specifically applicable to certain functions.

Selection of setting items

















For meter setting, press the button  when the meter is shut down, and then turn the rotary switch to any position other than OFF. Under the setting mode, the auxiliary display zone on the screen will show setting items, while the main display zone will show factory defaults. Press the button  to change setting items, and press the button  to save settings (when the main display zone shows **SAVE**, the current item is saved successfully). Shut down the meter after setting is completed.

Table 4-1 Modification of meter settings

Setting item		Function	Default
APoF	Timing for shutdown	The setting range is 0~60 minutes. Use  or  to select the flicker digit, and use  or  to set number of the flicker digit; if the digit is set to be 0, automatic shutdown of the meter will be canceled.	5minutes
bLoF	Setting of backlight time	The setting range is 0~3600 seconds . Use  or  to select the flicker digit, and use  or  to set number of the flicker digit; if the digit is set to be 0, automatic switch-off of backlight will be canceled.	60 seconds
LtoF	Setting of flash light time	The setting range is 0~30 minutes . Use  or  to select the flicker digit, and use  or  to set number of the flicker digit; if the digit is set to be 0, automatic switch-off of flash light will be canceled.	5minutes
bEEP	Buzzer	Use  or  to select ON or OFF.	ON

FACE	Back to factory defaults	Use <input type="checkbox"/> ▲ or <input type="checkbox"/> ▼ to select ON or YES.	NO
-------------	--------------------------	---	----

Chapter five

Meter maintenance

This chapter introduces some basic maintenance steps. Meter repair, calibration and maintenance that are not covered in this manual should be done by experienced personnel. Please contact service centers authorized by our company for maintenance instructions not mentioned here.

General maintenance

- Clean the meter enclosure with wet cloth and mild detergent on a regular basis. Don't use an abrasive agent or solvent.
- Take out batteries, if the meter is not used for a long time.
- Impurities or moisture in plugholes can influence readings.

Following steps should be observed, for cleaning of connection ports:

- (1) Switch off power supply of the meter, and remove all test wires.
- (2) Clean impurities at the connection ports.
- (3) Clean each connection port with a new swab dipping in alcohol.

Battery replacement

This meter uses three LR6 (AA) alkaline batteries.

⚠Warning

In order to avoid electric shock or personal injury:

- Remove the test wires from the meter, before opening the battery cover.
- Tighten screws on the battery cover, before using the meter.

⚠Notice

- Old batteries can't be mixed with new ones for use.

- Pay attention to the battery direction to make sure batteries are installed according to polarity marks inside the battery box.
- Please take out batteries if the meter is not used for a long time.
- Dispose used batteries based on relevant local rules.

Following steps should be observed for battery replacement(refer to figure 4-1, 4-2 and 4-3)

1. Turn off the power of the meter and disconnect all test wires;
2. Lift the bracket, take out the lock key, and then turn the left screw on the battery cover 1/4 turn counterclockwise, and the right screw 1/4 turn clockwise Remove the battery cover;
3. Put three new batteries into the battery compartment;
4. Install the battery cover, turn the left screw 1/4 turn clockwise, and turn the right screw 1/4 turn counterclockwise to remove the battery Cover is locked.
5. Put the lock key into the bracket to prevent it from being lost.

Fuse replacement

⚠Warning

Defined fuses should be used to avoid personal injury and meter damage. 630mA/250V quick-acting fuses are used.

The plughole of mA is protected by a 630mA/250V quick-acting fuse. Following steps should be observed to check whether the fuse is blown:

1. Turn the rotary switch to the position of “ $\tilde{m}A$ ”;
2. Plug the black test wire into the plughole of “COM” and the red one into “mA”;
3. Measure resistance between test wires with an ohmmeter. If the resistance is about 2Ω , the fuse is O.K. If the meter indicates an open circuit, the fuse is blown.

Please take the following steps to replace a fuse (refer to figure 4-1, 4-2 and 4-3):

1. Turn off the power of the meter and disconnect all test wires;
2. Lift the bracket, take out the lock key, and then turn the left screw on the battery cover 1/4 turn counterclockwise, and

- the right screw 1/4 turn clockwise Remove the battery cover;
3. Gently pry up one end of the fuse and remove the fuse from the clip.
- NOTE: The fuse must be replaced with the same ampere, voltage and blowing speed rating.
4. Install the battery cover, turn the left screw 1/4 turn clockwise, and turn the right screw 1/4 turn counterclockwise to lock the battery cover.
 5. Put the lock key into the bracket to prevent it from being lost.

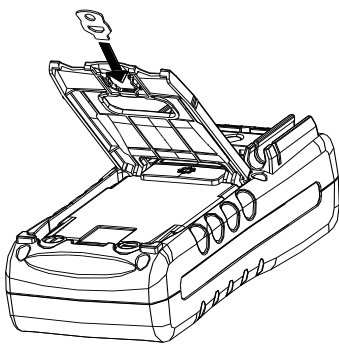

Figure 4-1 Remove the lock key

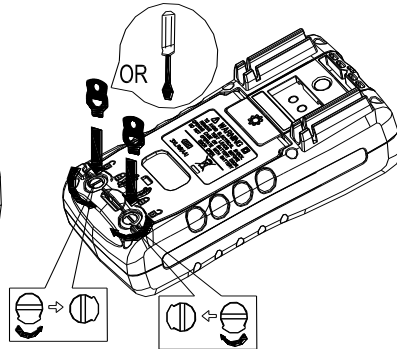

Figure 4-2 Remove the battery cover

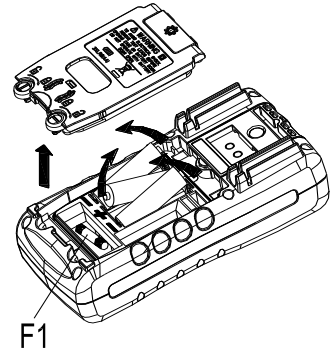

Figure 4-3 Replace the battery and the fuse

Chapter six

Technical specification

Safety and conformity

Overload protection	V~COM terminal: AC1000V/10 seconds mAV terminal: 630mA/250V quick-acting fuse
Regulatory compliance	IEC61010-1 (CAT IV 600V, CATIII1000V, pollution level II)
Electromagnetic compatibility	Consistent with Group 1 and Class B of IEC61326-1
Surge protection	8kV(As per IEC61010.1-2001)
Authentication mark	CE
Quality standard	It is developed, designed and produced according to ISO 9001.

General characteristics

Display	Digit: 4-digit display for measurement, 5-digit display for output
Display refreshing	Fast (F): 20times/second; slow (S): 5 times/second
Temperature and humidity range for work	0~40 °C, relative humidity \leq 85% (without moisture condensation)
Temperature and humidity range for storage	-20 °C ~ 60 °C, relative humidity below 90% (without moisture condensation)
Temperature and humidity range for guaranteed precision	23 \pm 5°C, relative humidity below 75% (without moisture condensation)
Temperature factor	0.1 \times basic precision / °C (temperature range: <18°C or >28°C)
Application environment	Indoors, outdoors (non-watertight), altitude of 0~2000m

Indication of outrange	OL
On-off/ open-circuit test	Buzzer beeps indicate the resistance reading is lower than the threshold, or an open circuit
Battery type	Three 1.5V (LR6) alkaline batteries
Service life of batteries	When using alkaline batteries Measuring any parameter: about 100mVA Loop detection function: about 200mVA DC current output (SIMULATE): about 200mVA DC current output (SOURCE) 20mA (1000 Ω load): about 1000mVA
Battery low	It is indicated with a battery mark.
Automatic shutdown	The meter is automatically shut down after about 5 minutes of no operation. The time can be adjusted.
Warm-up time	10 minutes
Close the meter enclosure calibration	No need for internal adjustment
Battery cover	For battery replacement, without influencing meter calibration
Size	185 (L) \times 90 (W) \times 54 (D) mm
Weight	About 500g
Calibrating period	1 year

Detailed precision indexes

Precision is affirmed within one year after calibration, with work temperature of $23\pm 5^{\circ}\text{C}$ and relative humidity of 75%.

A precision range can be marked as: \pm ([reading%] + count) (Note: “count” means increased or decreased number at the lowest significance digit)

Detailed precision indexes for measurement

Function	Range	Measuring scope	Resolution	Precision
DC voltage DCV	60mV	-60.00mV~60.00mV	0.01mV	0.2%+4
	600mV	-600.0mV~600.0mV	0.1mV	0.2%+4
	6V	-6.000V~6.000V	0.001V	0.2%+4
	60V	-60.00V~60.00V	0.01V	0.2%+4
	600V	-600.0V~600.0V	0.1V	0.2%+4
	1000V	-1000V~1000V	1V	0.2%+4
AC voltage ACV	6V	0~6.000V	0.001V	0.5%+40 (<400Hz) 5%+40 (>400Hz)
	60V	0~60.00V	0.01V	0.5%+4
	600V	0~600.0V	0.1V	0.5%+4
VFC	600V	0~600.0V	0.1V	4%+10
OHM	600 Ω	0~600.0 Ω	0.1 Ω	0.2%+4

	6k Ω	0~6.000k Ω	0.001k Ω	0.2%+4
	60k Ω	0~60.00k Ω	0.01k Ω	0.2%+4
	600k Ω	0~600.0k Ω	0.1k Ω	0.5%+4
	6M Ω	0~6.000M Ω	0.001M Ω	1%+4
	60M Ω	0~60.00M Ω	0.01M Ω	2%+4
DC current DCI	60mA	-60.00mA~60.00mA	0.01mA	0.2%+4
	600mA	-600.0mA~600.0mA	0.1mA	0.2%+4
AC current ACI	60mA	0.00mA~60.00mA	0.01mA	0.5%+10
	600mA	0.0mA~600.0mA	0.1mA	0.5%+10
Frequency FREQ	10Hz	0~9.9999Hz	0.0001Hz	0.02%+4
	100Hz	0~99.999Hz	0.001Hz	0.02%+4
	1000Hz	0~999.99Hz	0.01Hz	0.02%+4
	10kHz	0~5.0000kHz	0.0001kHz	0.02%+4
	DUTY	10%~90%	0.1%	1%
Diode	2V		0.0001V	1%+10
On-off test	600 Ω		0.1 Ω	$\leq 50 \Omega$ BB

1. AC measurement: true RMS, 20Hz~1kHz, VFC measurement: true RMS, 20Hz~200Hz, range of 10%~110%;
2. The thermocouple measurement adopts the thermometric scale of ITS-90. The precision doesn't include errors in cold-end compensation, or influences of thermo-electrical potential.
3. The thermal resistance measurement adopts the thermometric scale of Pt100-385. The precision doesn't include errors due to lead resistance.
4. During frequency measurement, for signals with frequency lower than 3Hz, relevant readings will be zero.

Detailed precision indexes for output

Function	Range	Output setting scope	Resolution	Precision	Remark
DC voltage DCV	100mV	-10.00~110.00mV	10 μ V	0.2%+4	Maximum output current 0.5mA
	1000mV	-100.0~1100.0mV	100 μ V	0.2%+4	Maximum output current 2mA
	10V	-1.000~11.000V	1mV	0.2%+4	Maximum output current 5mA
DC current DCI	30mA	0.000~33.000mA	0.001mA	0.2%+4	20mA, maximum load 1k Ω 30mA, maximum load 600 Ω
Simulated transmitter SIMULATE	-30mA	0.000~-33.000mA	0.001mA		
Loop power LOOP	24V			\pm 10%	Maximum output current 35mA

Frequency FREQ	100Hz	1.0Hz~110.0Hz	0.1Hz	0.2%+2 0.2%+2	Rectangular wave, duty cycle of 50% 1~11Vp-p
	1kHz	0.100kHz~1.100kHz	1Hz		
	5kHz	1.00kHz~6.00kHz	10Hz		
	10kHz	6.0kHz~11.0kHz	100Hz		
1.Load characteristics: capacitive loads $\geq 0.01\mu\text{F}$.					

Input characteristics

Function position	Input impedance (nominal value)					
V	10M Ω , <100pF					
mV	>2.5G Ω					
mA	1 Ω					
	Common-mode rejection ratio			Series-mode rejection ratio		
DCV、DCmV	80dB (dc to 50Hz / 60Hz/1K Ω)			40dB (50Hz / 60Hz)		
ACV、ACmV	60dB (dc to 50Hz / 60Hz/1K Ω)					
	Open-circuit voltage			Full-scale voltage		
Ohm	2.5V			2.2V		
Diode	< 3.5V			2.2V		
On-off	< 1V			600mV		
	Typical short-circuit current					
Ohm	600 Ω	6k Ω	60k Ω	600k Ω	6M Ω	60M Ω
	0.8mA	0.2mA	20 μ A	2 μ A	0.2 μ A	< 0.1 μ A
Diode	0.2mA (typical value)					

Notice of the Instruction Manual

- The present operation instruction is subject to change without notice.
- The content of the operation instruction is regarded as correct. Whenever any user finds its mistakes, omission, etc., he or she is requested to contact the manufacturer.
- The present manufacturer is not liable for any accident and hazard arising from the customer misuse or inadvertent operation.
- The functions described in this operation instruction should not be used as grounds to apply this product to a particular purpose.



elma instruments

Elma Instruments A/S

Ryttermarken 2
DK-3520 Farum
T: +45 7022 1000
info@elma.dk
www.elma.dk

Elma Instruments AS

Garver Ytteborgsvei 83
N-0977 Oslo
T: +47 22 10 42 70
firma@elma-instruments.no
www.elma-instruments.no

Elma Instruments AB

Pepparvägen 27
S-123 56 Farsta
T: +46 (0)8-447 57 70
info@elma.se
www.elma.se